

NAWTEC18-3567

**HIGH EFFICIENCY WASTE TO ENERGY POWER PLANTS COMBINING MUNICIPAL
SOLID WASTE AND NATURAL GAS OR ETHANOL**

Sergio Guerreiro Ribeiro
University of Brasil – COPPE-UFRJ
Rio de Janeiro, RJ 21945-970, Brazil

Tyler Kimberlin
Omega Energy Consulting
Fort Collins, CO 80525, USA

18th Annual North American Waste-to-Energy Conference
May 11-13, 2010, Orlando, Florida, USA

**CAN WTE BE ATTRACTIVE WITHOUT EUROPEAN
TIPPING FEES?**

**CAN EFFICIENCY IMPROVEMENT OCCUR WITHOUT
HIGH COSTS?**

**CURRENTLY WTE IS UNFEASIBLE IN DEVELOPING
COUNTRIES (US\$ 20/TON) AND ECONOMICS NOT
ATTRACTIVE TO IMPROVE USA SITUATION
(US\$ 50/TON).**

**GLOBAL ECONOMY CRISIS WILL NOT HELP THAT
AND LOWERING THE COSTS, WITH HIGHER
EFFICIENCY, IS MANDATORY.**

EFFICIENCY IMPROVEMENT

1. ADVANCED STEAM PARAMETERS

2. LOW EXCESS AIR

3. LOW STACK TEMPERATURE

CARNOT → HIGHER EFFICIENCY → Q_{in} @ HIGH TEMP (HIGHER P_{max})
 Q_{out} @ LOWER TEMP (LOWER P_{cond})

WTE → $T_{E'} < 400$ C → HIGH MOISTURE AT STEAM TURBINE LAST STAGES.

STEAM TURBINES WITH LOWER ISENTROPIC EFFICIENCY IMPROVES THAT (?)

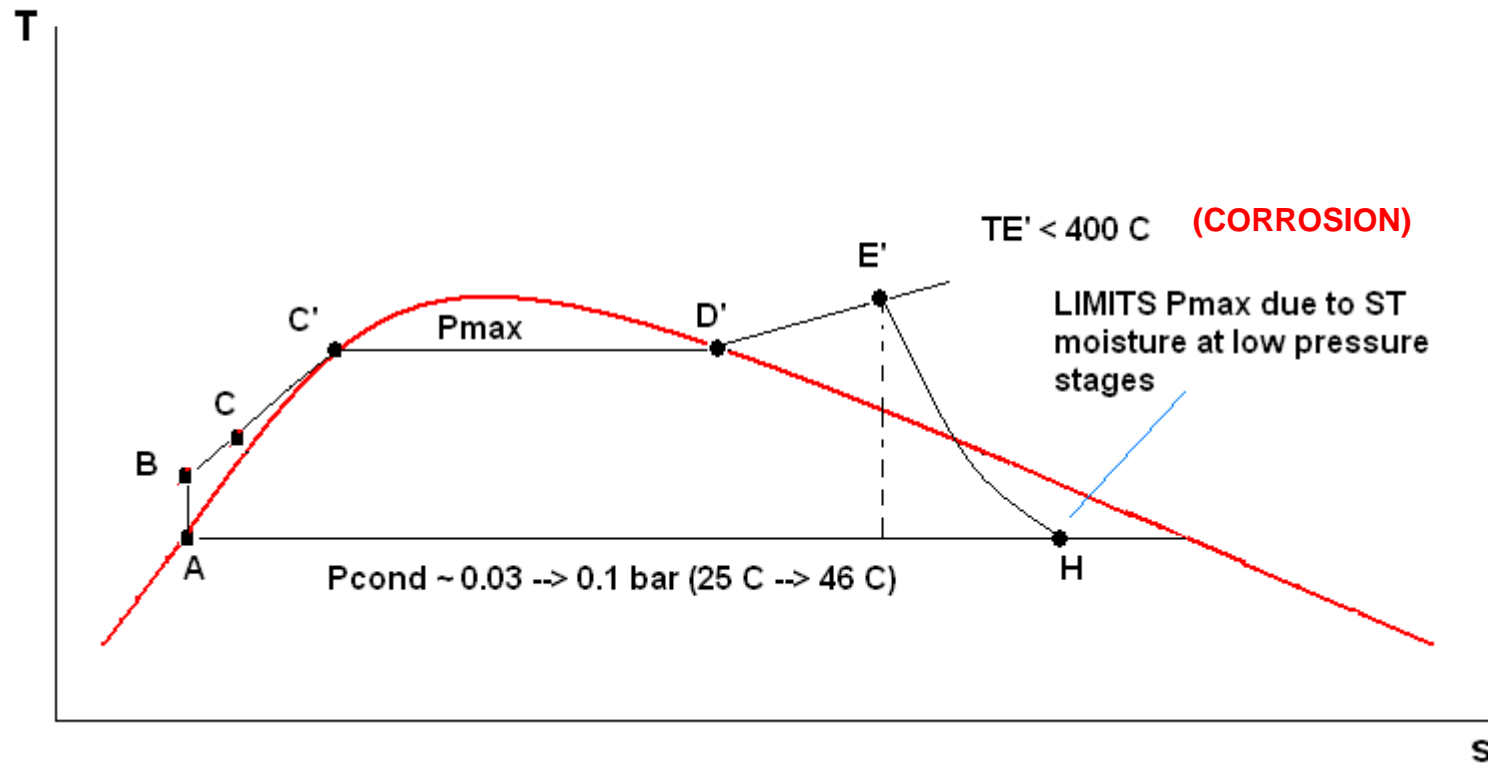

SOLUTION → REHEAT STEAM CYCLE

REHEATING ALLOWS HIGHER PRESSURE (TEMP) $Q_{in} \rightarrow$ CARNOT EFF.

LOWER MOISTURE AT ST EXIT \rightarrow HIGHER ISENTROPIC EFF

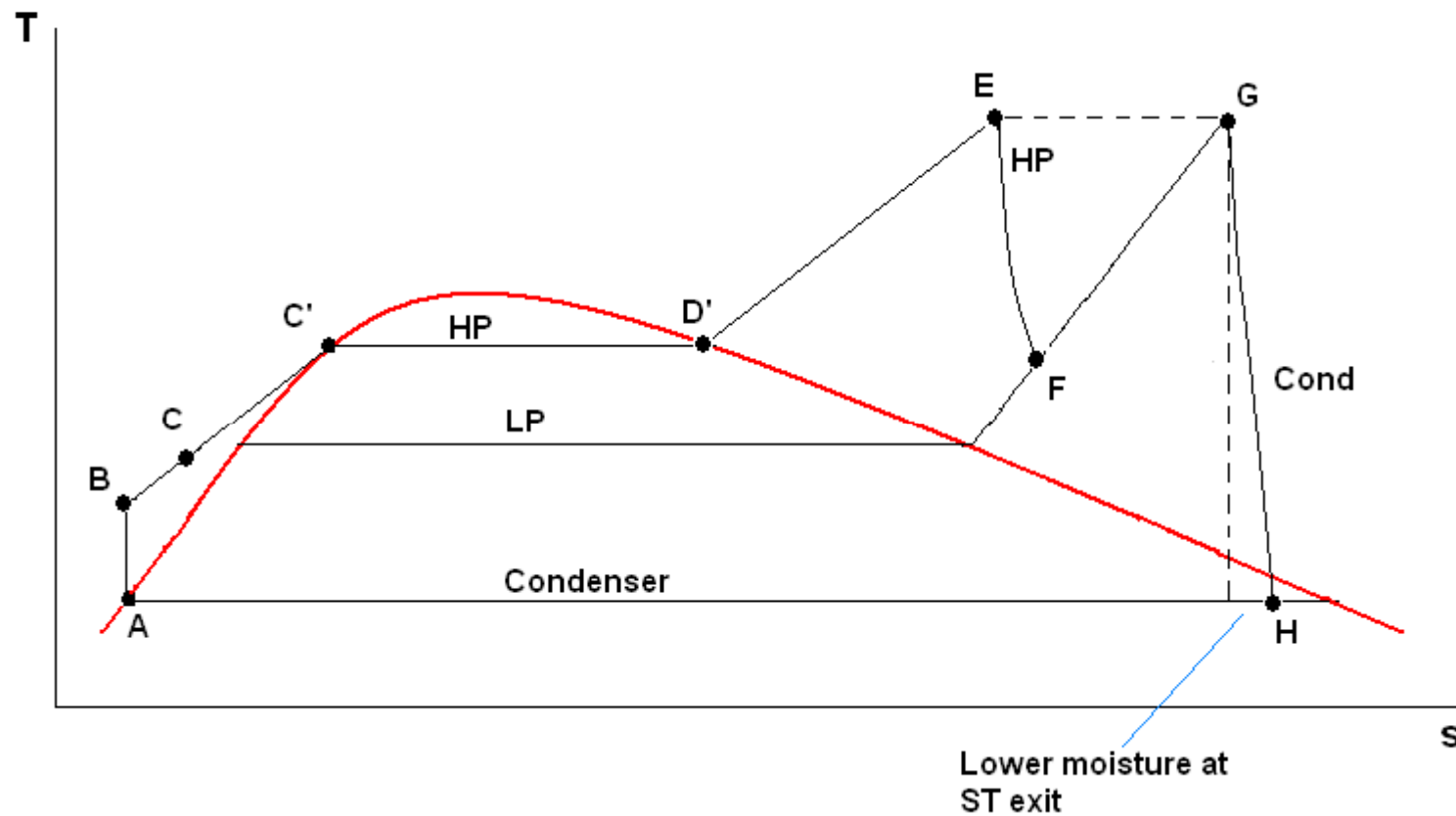

PROBLEM \rightarrow IN THE PAST ONLY AVAILABLE FOR LARGE PLANTS (> 200 MWe)

SIEMENS HAS DEVELOPED HIGH EFFICIENCY MEDIUM SIZE STEAM TURBINES FOR BIOMASS PLANTS IN EUROPE USING REHEAT STEAM CYCLES. HOWEVER ECONOMICS REQUIRES HIGH STEAM TEMPERATURE (480-540 C).

BIOMASS LOOKING FOR EFFICIENT UTILIZATION –THE REHEAT CONCEPT

Jaroslav Lahoda, Olaf Arndt, Walter Hanstein

Siemens Power Generation (PG)

Steam reheating

Reheating is common a means to improve plant efficiency in larger power plants, and has cently also been used in smaller power plants.

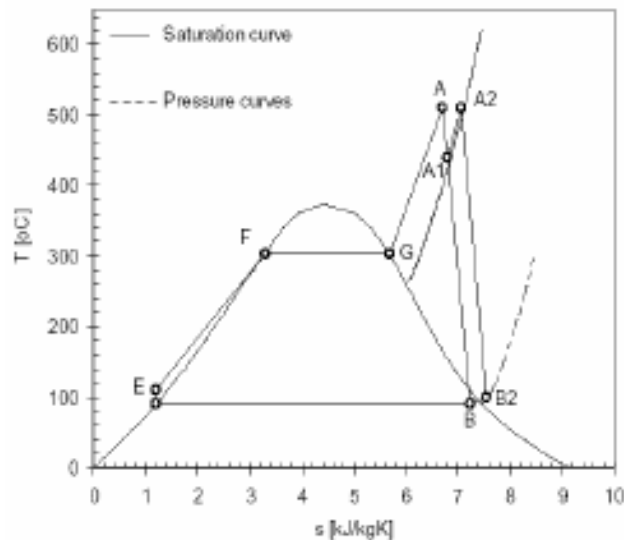

Figure 3: *T,s* diagram of the steam reheater

ISENTROPIC EFFICIENCIES ~ 85% - 90%

SST-PAC 400 reheat turbosets

With such references as:

Königs Wusterhausen	20 MWeI, Germany
Bischofferode	20 MWeI, Germany
Eberswalde	21 MWeI, Germany
Simmering	23 MWeI, Vienna /Austria

SST-PAC 400 reheat turbosets are the most successful solution in the biomass power plant market with reheat cycles.

AMSTERDAM WFPF MOST SUCCESSFUL EXAMPLE OF REHEAT APPLIED TO WTE.



Case Study: Steam Turbines for Waste-to-Energy



The LP rotor under assembly in the Swedish workshop. The diameter of the last stage blades is the largest fabricated for this type of turbine.

The culmination of Amsterdam's long experience with waste incineration is the world's first Waste Fired Power Plant (WFPF®), a new facility designed to transform waste with high efficiency into energy and building materials.



Left: The SST-700 RH installed in the plant, showing noise enclosure (red) over the HP-module, generator and gear.



Right: SST-700 LP-module, condenser (green), LP inlet (silver), LP exhaust (brown).

Reheat turbine for high efficiency

A Siemens SST-700 reheat solution was selected in 2003 for the 4th generation WFPF. The 74 MW SST-700RH turbine is an extraction condensing machine used in reheat configuration. It consists of one geared high-pressure (HP) module and one direct-drive low-pressure (LP) module.

The plant was designed to burn 940.000 tonnes of waste per year at an efficiency of 22%. In 2007, with the SST-700RH at the heart of the process, this has increased to 1.5 million tonnes at an efficiency of 30%.

SIEMENS

**REHEATING TO HIGH TEMPERATURES (> 400 C)
WITHOUT EXTERNAL SUPERHEATER →
CORROSION (HIGH O&M)**

**REHEATING WITH EXTERNAL SUPERHEATER
(USING CLEAN FUEL) → EXCESSIVE
CONSUMPTION OF NATURAL GAS (FOSSIL)**

WFPP IN AMSTERDAM – HIGHEST EFFICIENCY (NO EXTERNAL SUPERHEATER)



**BOTH PLANTS
 30% EFF FOR
 WASTE SHARE.**



Figura 4.2 – Usina WTE de Amsterdam (4.500 ton/dia).

BILBAO-COMBINED CYCLE (EXTERNAL SH) - 78% OF TOTAL ENERGY FROM NG

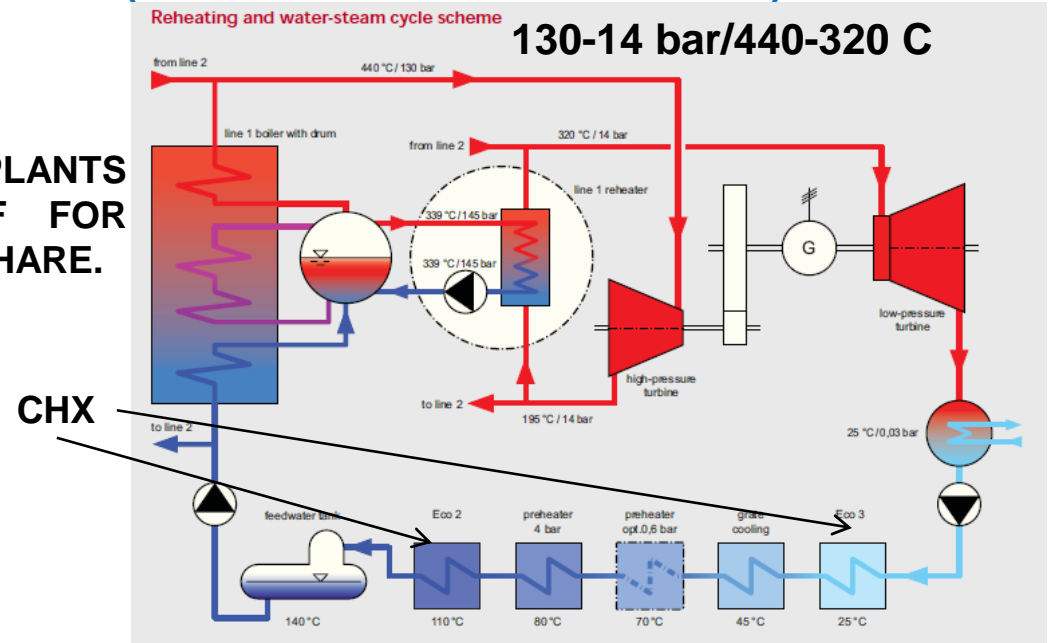
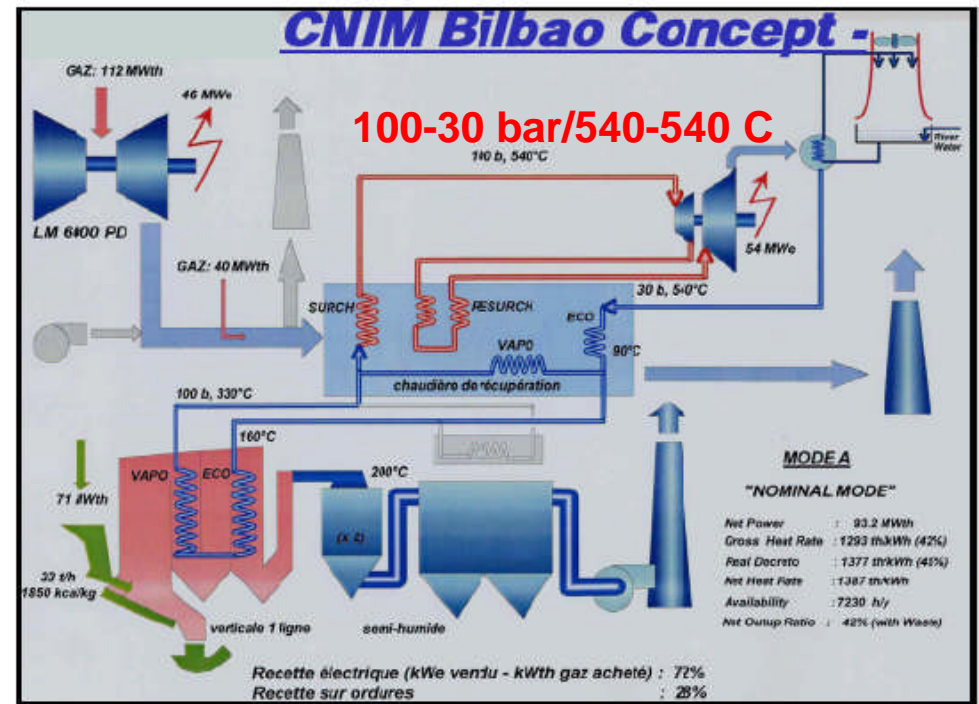

RÜDERSDORF → REHEATING ONLY NOT EXTERNAL SUPERHEATING → NET EFFICIENCY 29%.

Waste-to-Energy Plant
Germany
EBS-IKW Rüdersdorf



- Steam generation: 120.3 Mg/h (90 bar/420 °C)
- MP-steam reheating: 115 Mg/h (23 bar/420 °C)
- High energy efficient steam process with MP-steam reheating and low steam condensing pressure 0.068 bar_a

SAKAI → EXTERNAL SUPERHEATING ONLY – FEED WATER HEATING INSTEAD OF ADDITIONAL STEAM

ENERGY LOSS – CLEAN GASES LOW O₂

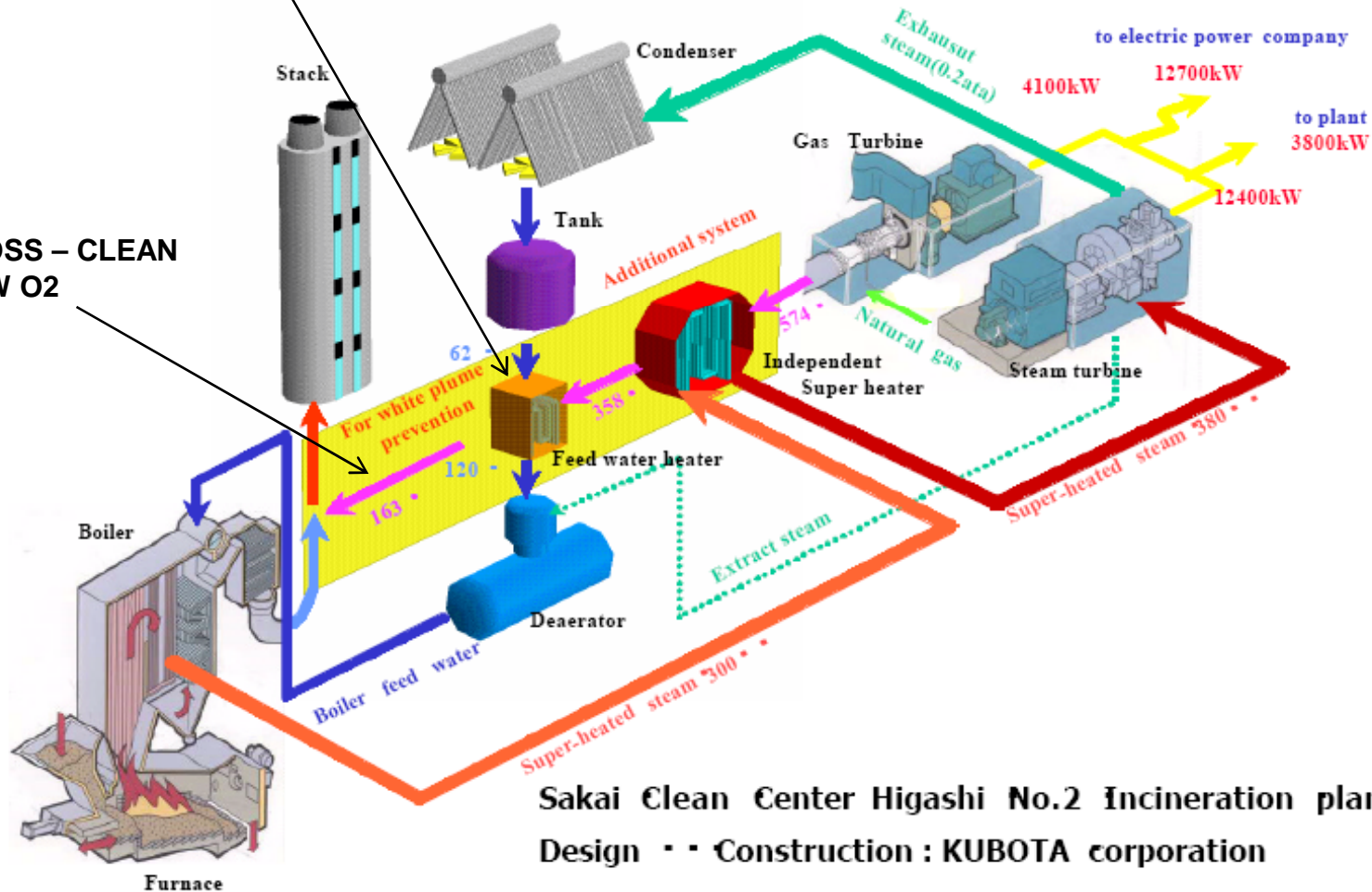

Sakai Clean Center Higashi No.2 Incineration plant
 Design - - Construction : KUBOTA corporation

PREVIOUS SOLUTIONS

ADVANTAGES

1. HIGH EFFICIENCY THROUGH REHEATING (WFPP, BILBAO, RÜDERSDOF)
2. EXTERNAL SUPERHEATING - NO CORROSION IN WASTE BOILER (BILBAO, SAKAI)
3. CONDENSING HEAT EXCHANGER AND ECONOMISERS – CHX (WFPP, SAKAI)

DISADVANTAGES

1. HIGH TEMPERATURE IN WASTE BOILER SH – CORROSION (WFPP, RÜDERSDOF)
2. TOO MUCH NG – FOSSIL FUEL (BILBAO)
3. GRID OPERATOR MAY NOT DISPATCH LARGE NATURAL GAS TURBINE IF RENEWABLE SOURCE IS AVAILABLE AT LOWER COST (HYDROPOWER IN BRAZIL) (BILBAO)

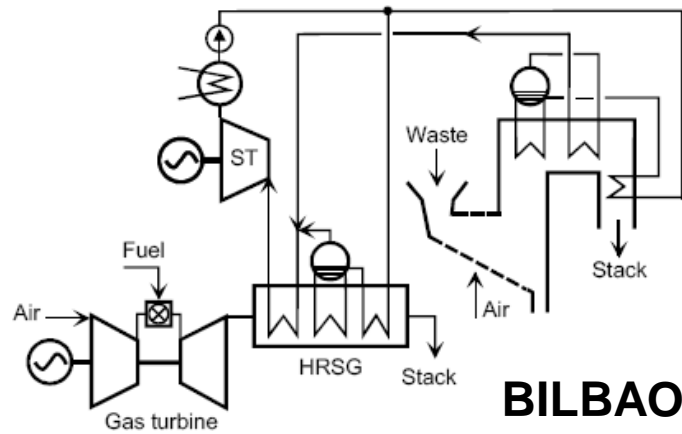

Fig. 6.2. HRS-Incineration boiler parallel configuration (Case 1).

**KOROBITSYN –
COMBINED CYCLES
1998
(NO REHEATING)**

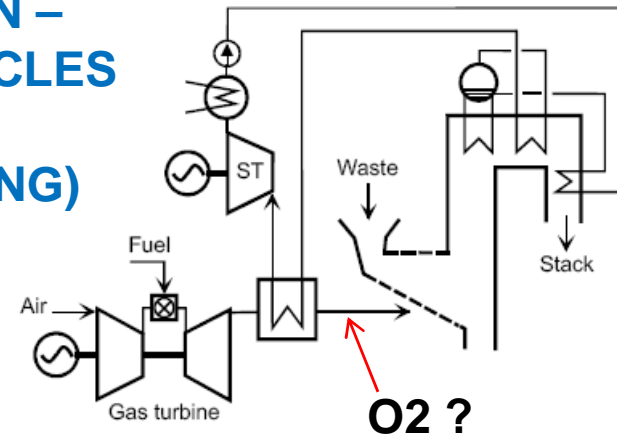

Fig. 6.3. The hot windbox configuration with superheating (Case 3).

THE GT USED IN THE WORK IS NOT AVAILABLE. IN BILBAO (CASE 1) DUCT BURNING IS USED TO REACH HIGH STEAM TEMP. MSW SHARE DROPS TO 22% .

IS IT POSSIBLE TO REDUCE NG SHARE AND KEEP HIGH EFFICIENCY WITH LOW COST? BEST CANDIDATE IS CASE 3.

Table 6.3. Summary of results (scaled).

	Reference	Case 1	Case 2	Case 3	Case 4
Fuel input, MWth					
· incineration boiler	92.00	92.00	92.00	92.00	92.00
· gas turbine	0.00	<u>100.14</u>	101.39	<u>48.44</u>	104.73
Total	92.00	192.14	193.39	140.44	196.73
MSW share, %	100.00	47.88	47.57	65.51	46.76
Natural gas share, %	0.00	<u>52.12</u>	52.43	<u>34.49</u>	53.24
Power output, MWe					
· steam turbine	22.92	46.46	46.92	36.89	47.79
· gas turbine	0.00	31.96	32.37	15.48	33.44
Total	22.92	78.42	79.29	52.36	81.23
Efficiency, %					
· based on total input	24.91	40.81	41.00	37.28	41.29
· based on MSW	24.91	28.64	28.88	<u>29.54</u>	29.10
Specific surface area, m²/MWe					
	294	710	686	<u>340</u>	518

LOWER COST

OPTIMIZED COMBINED CYCLE – OCC - NG / MSW

START WITH WASTE BOILER PRODUCING HIGHER PRESSURE STEAM AND CORROSION RESISTANT CONDENSING HEAT EXCHANGER AIR PREHEATER.

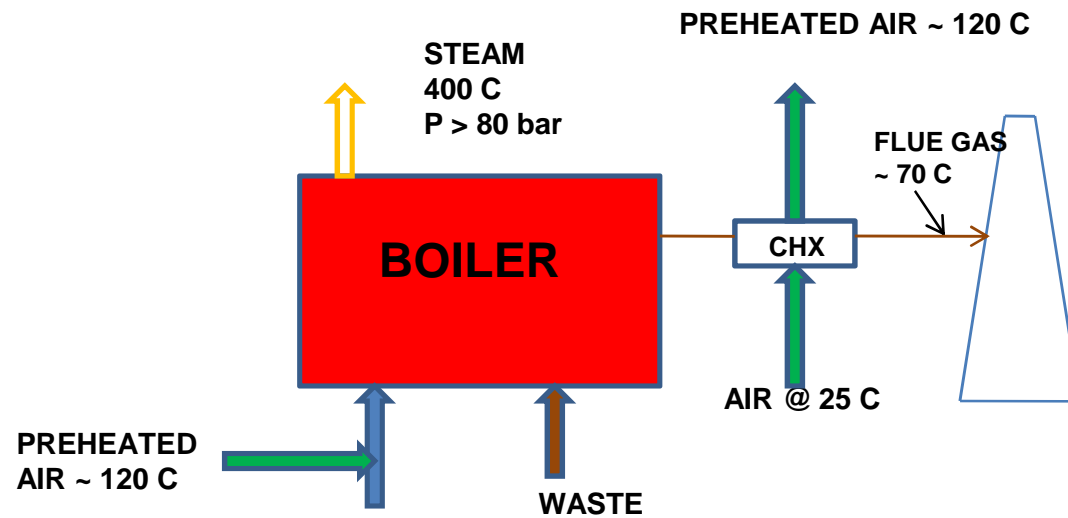

OPTIMIZED COMBINED CYCLE – OCC - NG / MSW

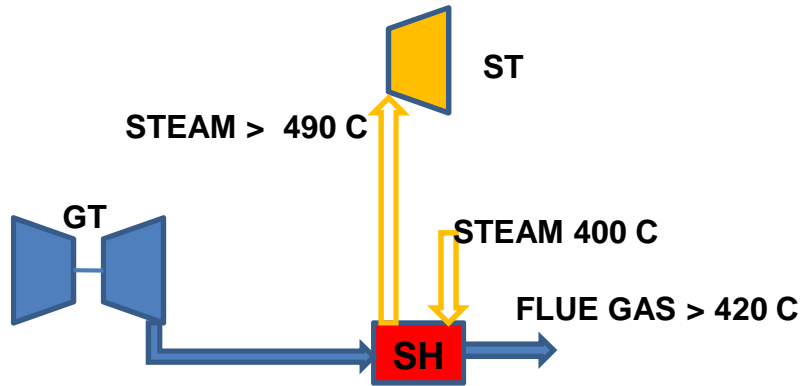

INTRODUCE SMALL GT AROUND PLANT SELF LOAD. NOT POSSIBLE TO USE EXHAUST TO SUPERHEAT WASTE BOILER PRODUCED STEAM.

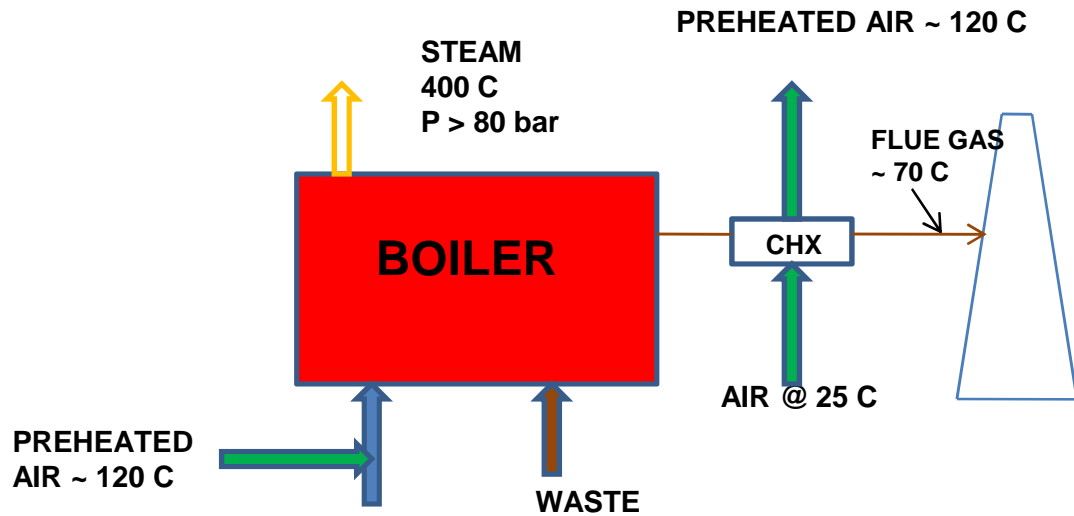

OPTIMIZED COMBINED CYCLE – OCC - NG / MSW

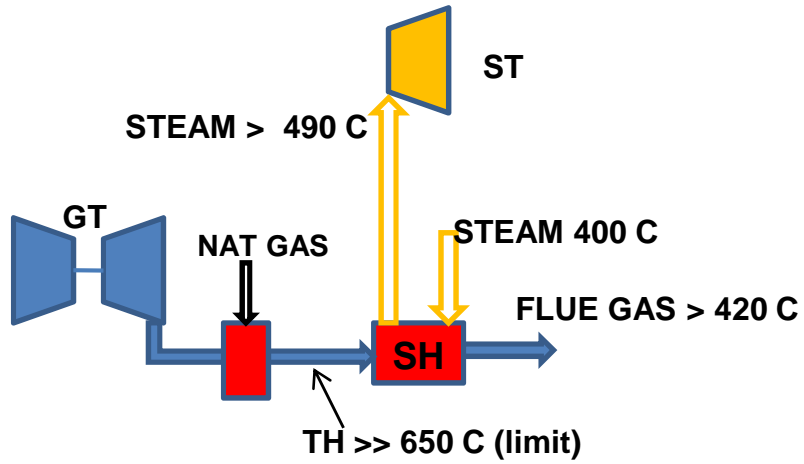

EVEN INTRODUCING DUCT BURNERS THE FLUE GAS TEMP WILL BE TOO HIGH TO SUPERHEAT LARGE AMOUNT OF STEAM FROM WASTE BOILER.

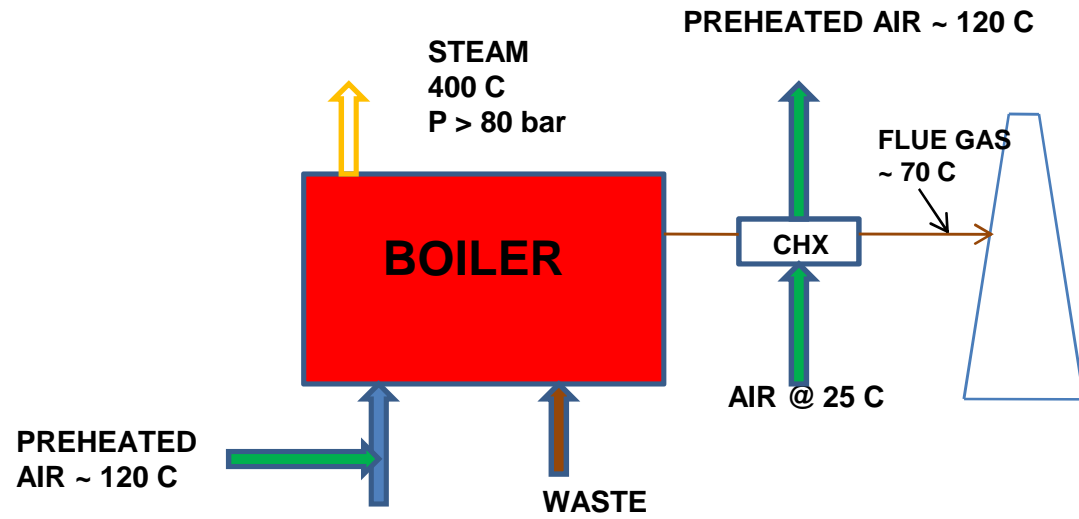

OPTIMIZED COMBINED CYCLE – OCC - NG / MSW

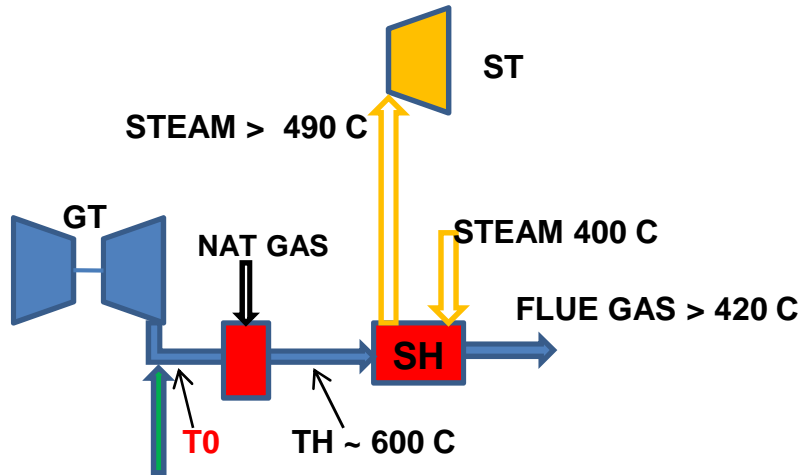

FRESH AIR → T0 VERY LOW → TOO MUCH NG.

WE WILL NEED HIGHER FLOW TO KEEP TEMP AFTER THE BURNER BELOW 650 C. IF USE AMBIENT AIR → TOO MUCH NG IN THE BURNER.

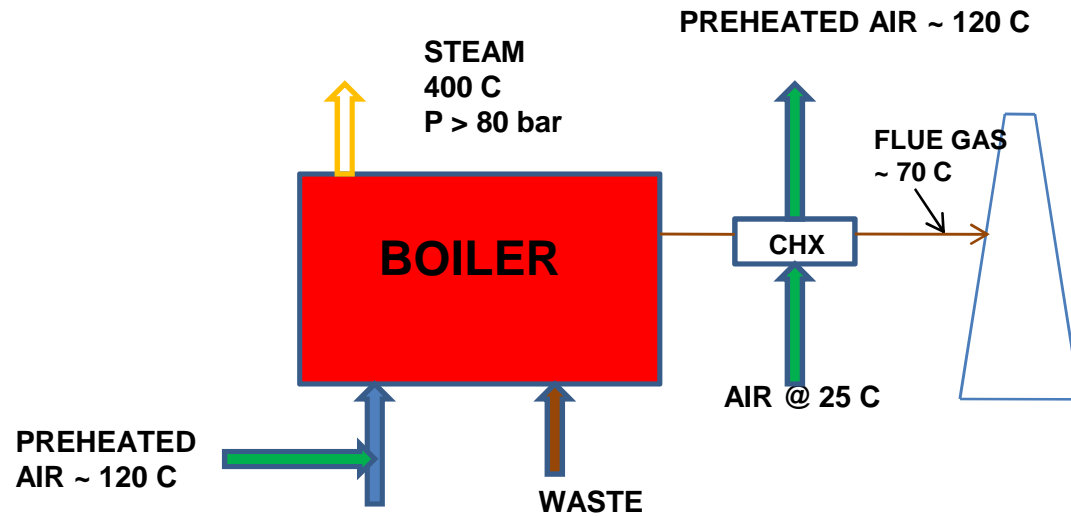

OPTIMIZED COMBINED CYCLE – OCC - NG / MSW

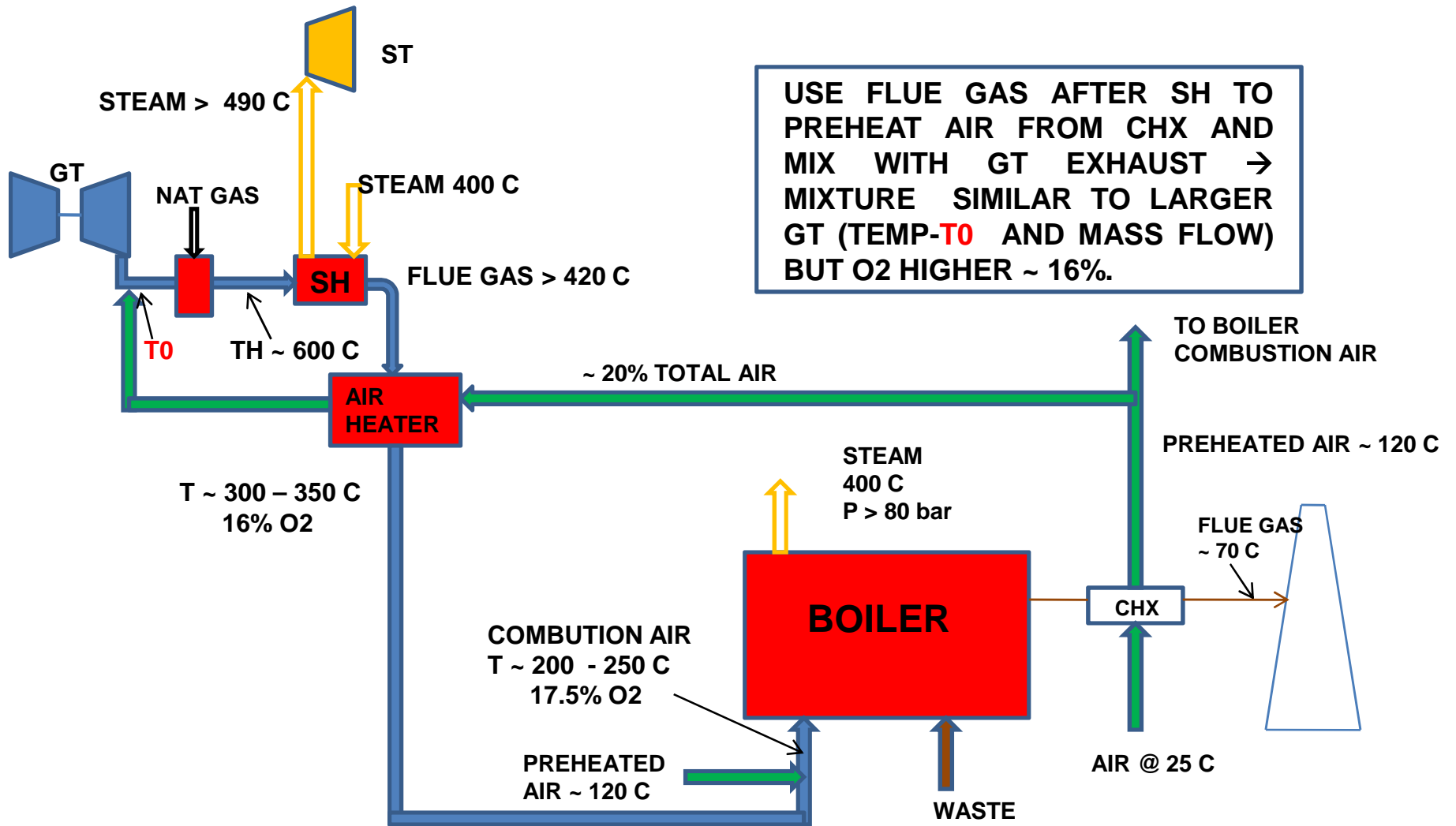

OPTIMIZED COMBINED CYCLE – OCC - NG / MSW

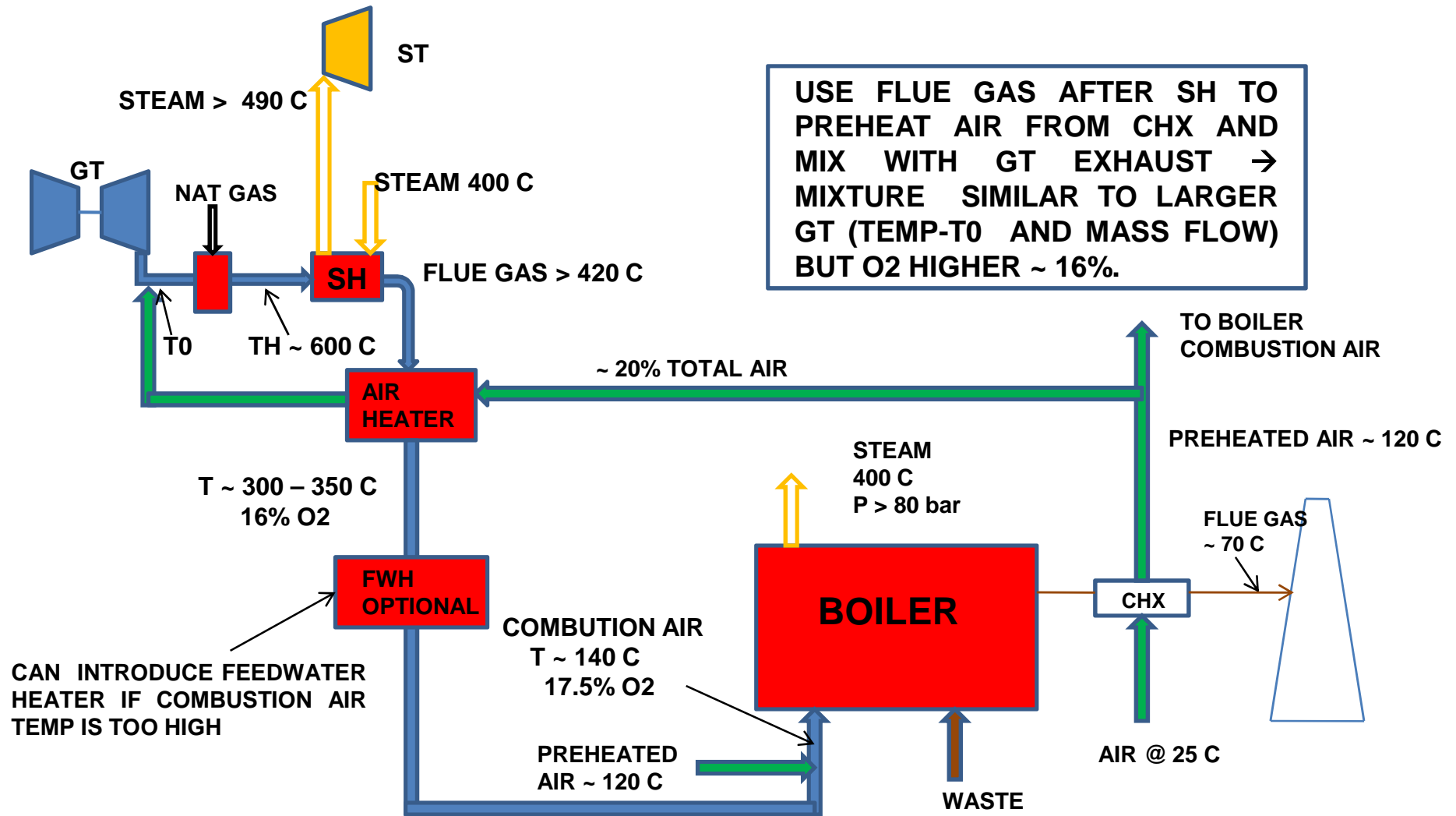

CHOICE OF GT X NG COST IS VERY IMPORTANT TO OPTIMUM DESIGN → NEED **DEDICATED SOFTWARE TO INCLUDE FINANCE.**

OPTIMIZED COMBINED CYCLE – OCC - NG / MSW

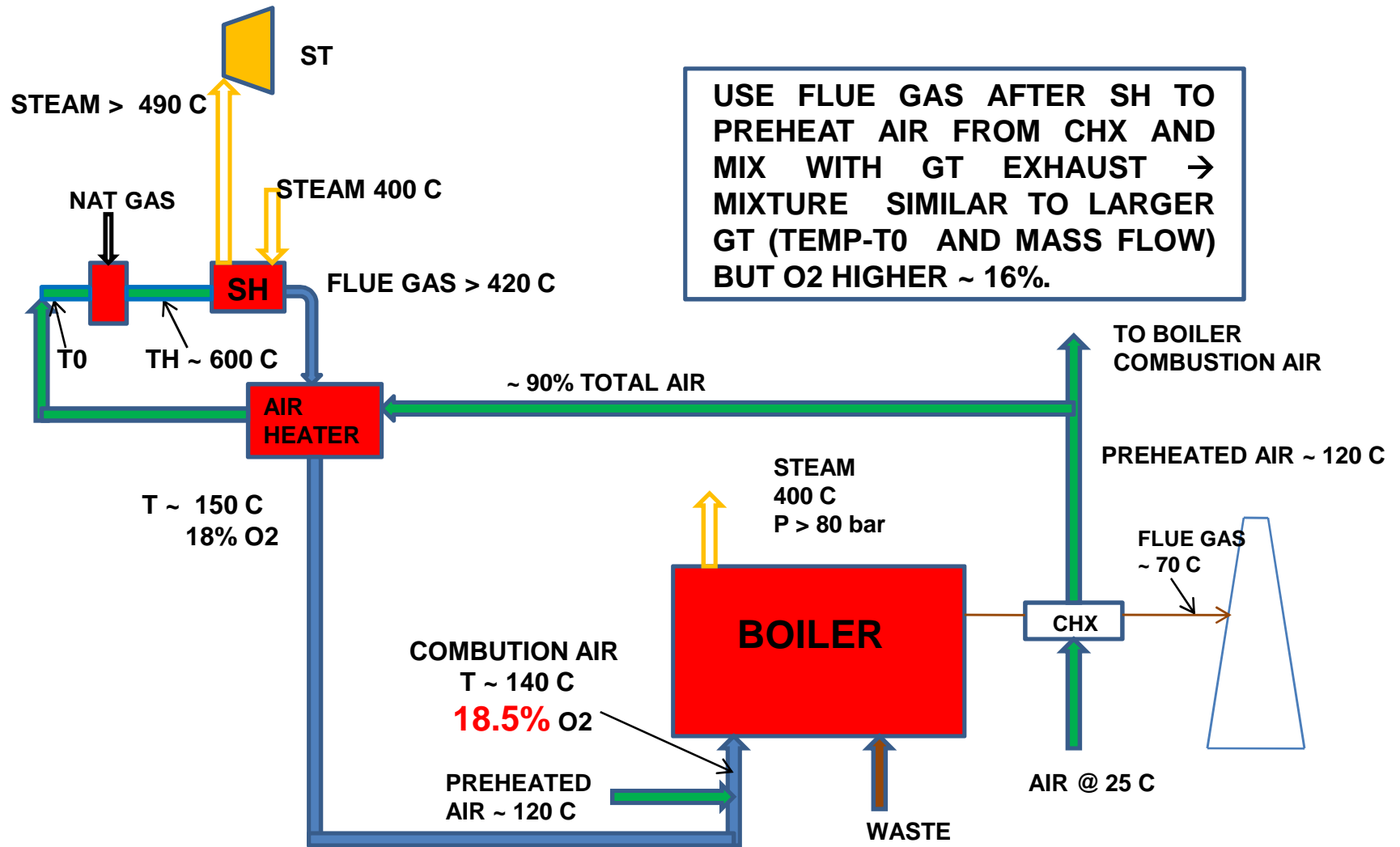

IF “NATURAL GAS” IS LOW COST (LANDFILL GAS) WE CAN REMOVE THE GT – GAS SHARE SMALL, LESS THAN 15% OF TOTAL POWER. GAS EFFICIENCY LIMITED BY STEAM CYCLE BUT IRR CAN BE HIGHER.

OCC DEDICATED SOFTWARE – PLANT CONFIGURATION

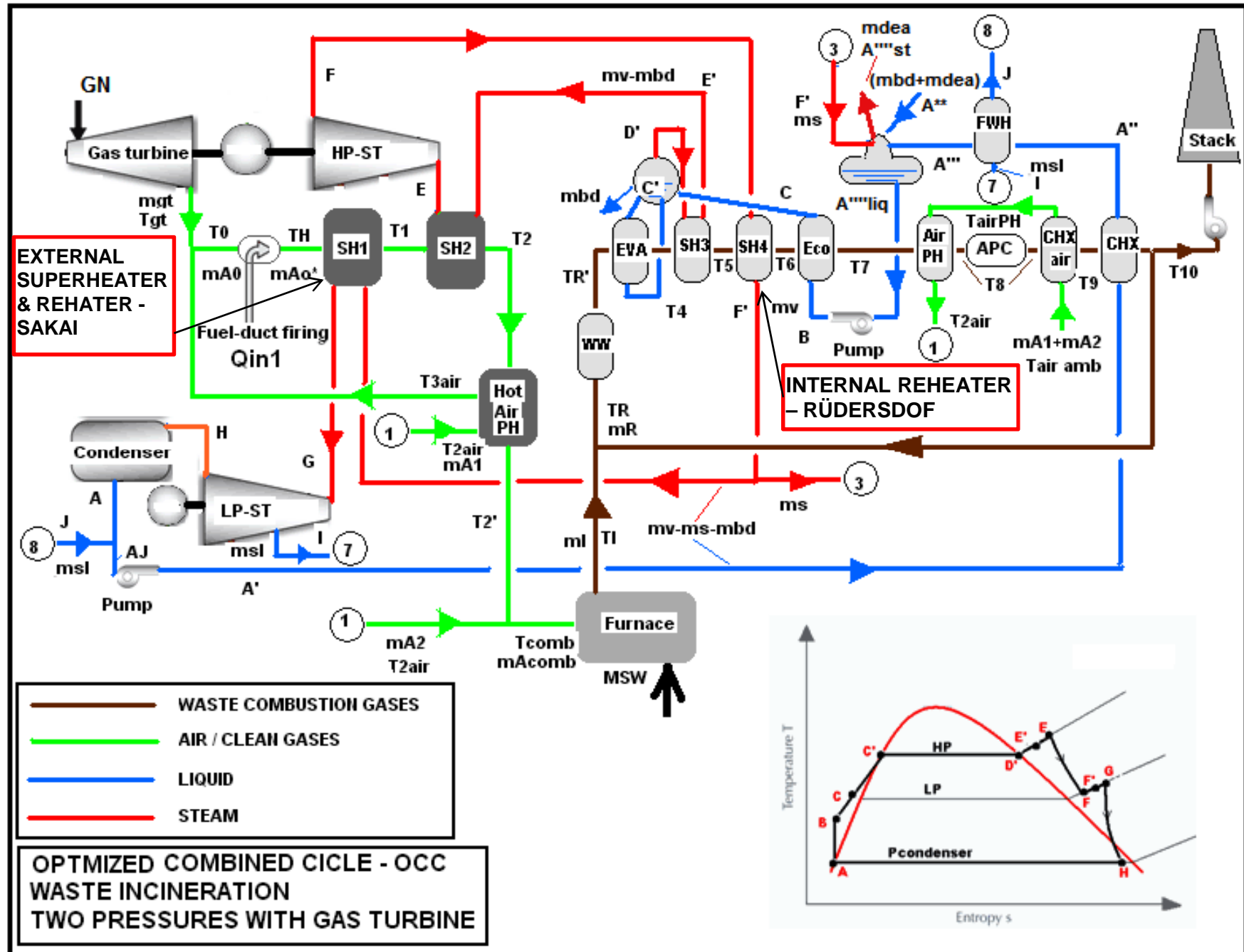

GATECYCLE MODEL TO VALIDATE OCC DEDICATED SOFTWARE (850 TPD)

MODEL: BZL1-2
CASE: BZL1-2
POWER: 34.31
HR: 10081.0
EFF: 35.71

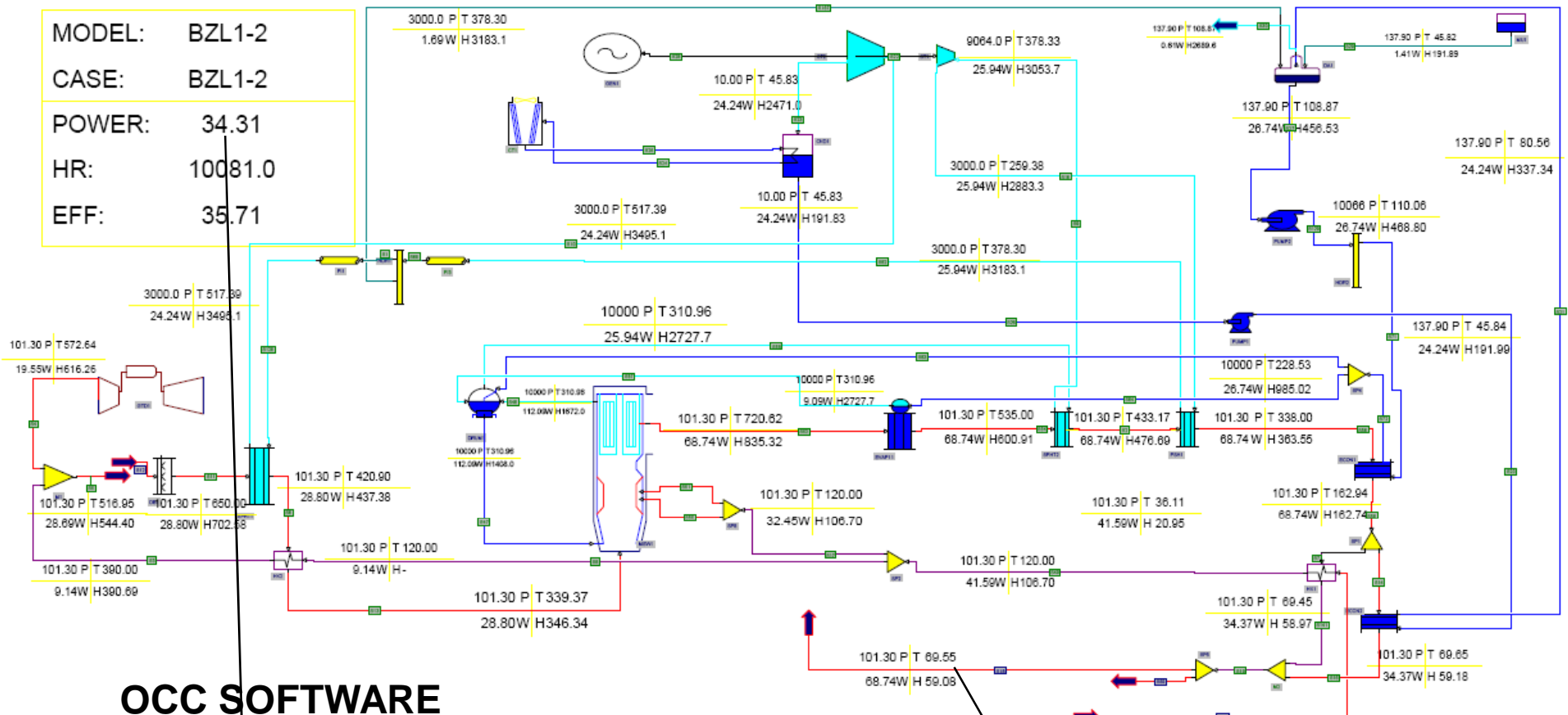

OCC SOFTWARE

POWER

	MWe
GT or GE	5,500
HP st	4,297
LP st	24,530
TOTAL	34,327
Self Load	0,000
Net Power	34,327
MSW Power	23,650
NG Power	10,677

ENERGY INPUT

	MWth
GT or GE	17,915
Burner	4,632
TOT NG	22,547
MSW	76,191
MSW eff	31,04%
NG eff	47,36%
Overall eff	34,77%

STACK CONDITIONS	TEMP (C)	O2 (%)	H2O (%)
GATECYCLE	69.55	6.70	17.61
OCC SOFTWARE	68.69	6.64	17.83

COMPARISON BETWEEN BILBAO AND OCC – SAME MSW BOILER

	CASE1	CASE2	CASE3	CASE4
	BILBAO PLANT ORIGINAL	OCC BILBAO (STANDARD ST)	OCC BILBAO (HIGH EFF ST)	OCC BILBAO (HIGH EFF ST) no GT
TPD	792	792	792	792
GAS TURBINE(MWe)	LM6000 (46)	GE5 (5.5)	GE5 (5.5)	NA
HP (bar) / T (C) / Isen eff	100 / 540 / NA	100 / 400 / 0.703	100 / 400 / 0.85	100 / 460 / 0.85
LP (bar) / T (C) / Isen eff / Pcond (bar)	30 / 540 / NA / NA	30 / 540 / 0.865 / 0.06	30 / 530 / 0.91 / 0.03	30 / 530 / 0.91 / 0.03
PLANT GROSS POWER(MWe)	100	33,89	36,17	30,05
MSW ENERGY (MWth)	71	71	71	71
Nat Gas CONSUMPTION(MWth)	152	21,84	21,32	12,38
MSW APP EFFICIENCY	31,66%	34,51%	38,04%	36,04%
Nat Gas EFFICIENCY - STANDALONE CC	51,00%	43,00%	43,00%	NA
MSW ACTUAL EFFICIENCY	NA	32,65%	35,48%	36,04%
Nat Gas ACTUAL EFFICIENCY	NA	49,06%	51,51%	36,04%
MSW SHARE	22,48%	72,30%	74,67%	85,15%
OVERALL EFFICIENCY	44,84%	36,50%	39,18%	36,04%

WTE **71MWth (22% eff)** → 15.6 MWe OCC(CASE4) **+12.38 MWth** → +14.45 MWe
NG (117%)

CASE 4 – WITHOUT GT – GOOD OPTION FOR LANDFILL GAS OR BIOGAS FROM ANAEROBIC DIGESTOR – “NG” CONSUMPTION ~ 8% OF BILBAO. IF LANDFILL GAS IS NOT AVAILABLE CAN USE ETHANOL / BIODIESEL SYNTHETIC NG.

SCHU & LEITHNER (2008) – LIGNITE (FOSSIL, HIGH MOISTURE) AND RDF – SIMILAR CONCEPT – AIR PREHEATING – REHEATING (150-40 bar / 540-540 C) – SPECIAL BOILERS - SAME RESULTS BUT →\$\$\$

4. WATER-STEAM-CYCLE BIFUELCYCLE

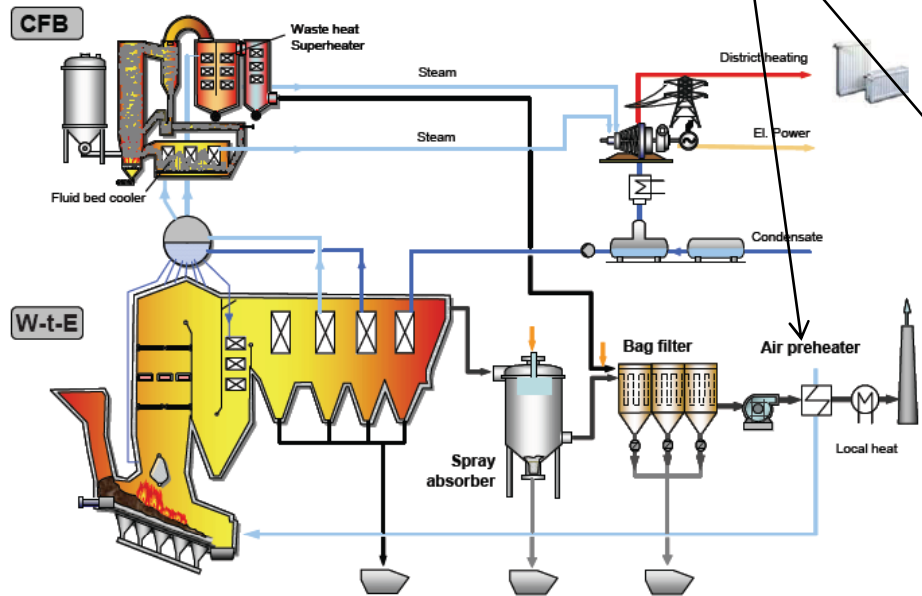
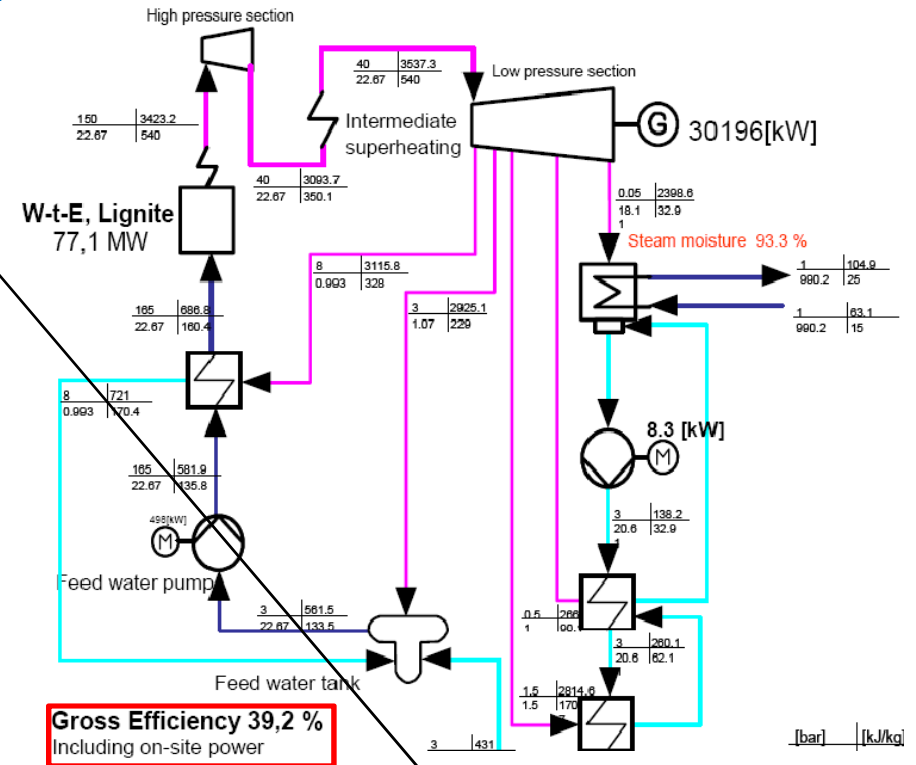
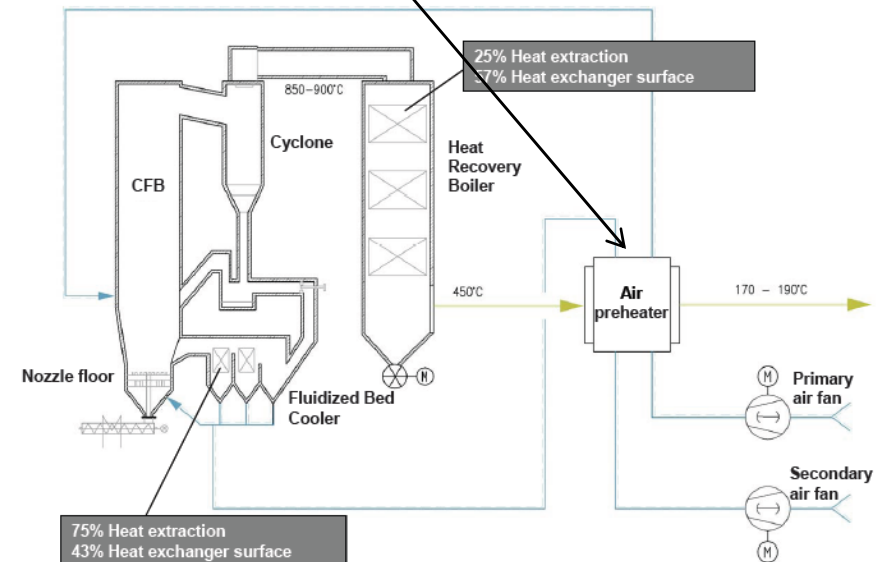
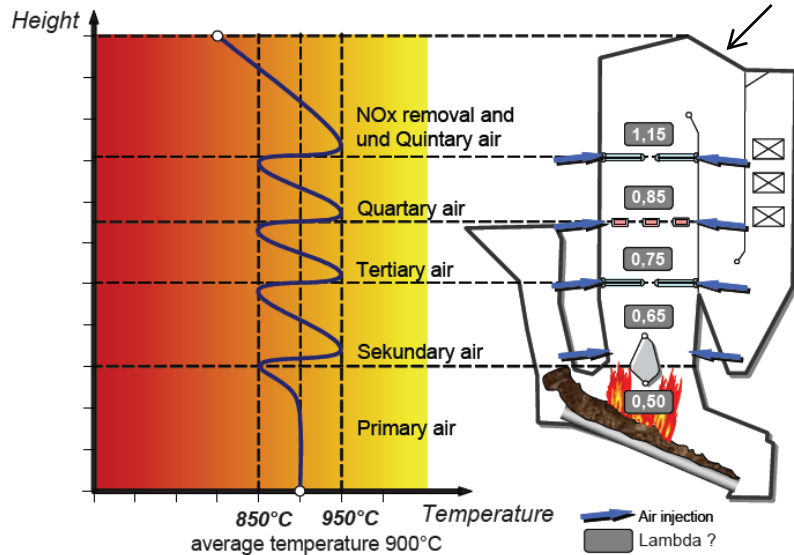



Figure 5. Process Flow Diagram BiFuelCycle



LAMBDA < 1.25



IF BIOGAS or NG NOT AVAILABLE WE CAN REPLACE WITH → LPP “NG” FROM ETHANOL OR BIOBIESEL (GLOBAL WARMING)



**Dispatchable Renewable Energy:
Gas Turbines Can Burn Liquid Biofuels
as Cleanly as Natural Gas**

**LPP Combustion
Columbia, MD.**

Renewable Energy World
March 10 - 12, 2009

What LPP Does For Liquid Fuels



Same Combustor Hardware



Natural Gas is known for providing Clean Energy.

The LPP System provides the same Clean Energy from Liquid Fuels.

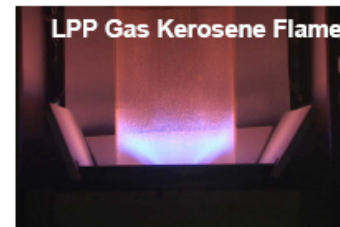

Slide 3

The LPP Solution



Urgent need exists in the power industry and energy markets to . . .

Burn Liquid Fuels at Natural Gas Emission Levels



- Fuel flexibility (Fuel Arbitrage)
- Improved heat rate (Efficiency)
- Reduced maintenance
- Contingency to NG Curtailment

Provide Dependable Green Power Solutions



- Cleanest use of renewable fuels (biodiesel, ethanol...)
- Use existing infrastructure
- “Dispatchable” renewable energy
- Meet RPS mandates

Conventional Liquid Fuel Flame



The Problem

Natural Gas Flame



The Goal

Liquid Fuel Flame Using the LPP System

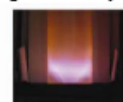

The Solution

LPP Combustion has developed a patented technology solution to produce clean energy from conventional, renewable and alternative liquid fuels

Slide 4

LPP Combustion Technology



LPP = Lean, Premixed & Prevaporized

- The LPP Combustion System converts liquid fuels into a synthetic natural gas (LPP Gas)
- This LPP Gas can then be burned with low emissions in place of natural gas in virtually any combustion device
- Burning biodiesel, the LPP System creates a low-emissions, renewable energy power plant with no net CO₂ gas emissions

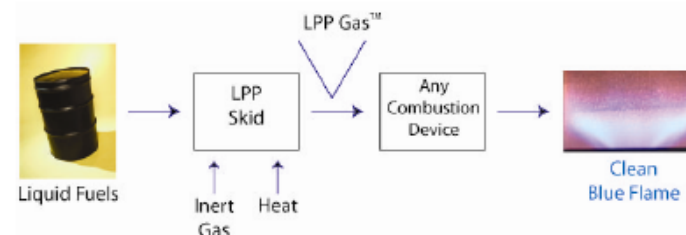

Slide 5

HIGH MOISTURE WASTE **COST LESS** TO BURN PER TON

	APROX. WASTE COMP			LHV MJ/Kg	Tadiabatic = 1,200 C		AIR FUEL RATIO			APC/BOILER COST INDEX	GRATE/ BOILER COST INDEX (C6H10O4+ASHES)
	C6H10O4	H2O	ASHES		Excess Air (lambda)	Stack O2 (Volume)	Ton air/Ton C6H10O4	Ton air/Ton WASTE	Ton FG/Ton WASTE		
BRAZIL	52%	33%	15%	8,0	1.36	4,42%	8.53	4.436	5.29	0.71	0.82
EUROPE	62%	23%	15%	10,0	1.52	6,02%	9.52	5.901	6.75	0.90	0.94
USA	67%	18%	15%	11,0	1.58	6,60%	9.92	6.643	7.49	1.00	1.00

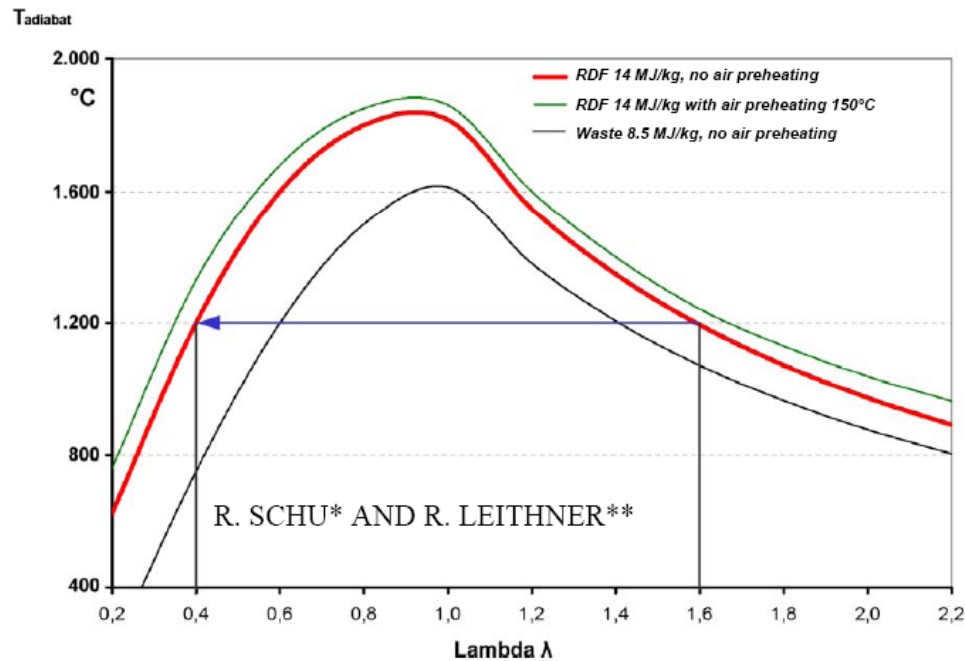

ONE TON OF BRAZILIAN WASTE → 22% LESS DRY FUEL (C6H10O4) THAN USA
(NEED LESS AIR TO BURN)

→ 83% MORE WATER THAN USA
(NEED LESS AIR TO COOL)

CONCLUSIONS

1. HIGHER MOISTURE MSW → SMALLER APC / BOILER.

2. WTE IN BRAZIL / CHINA SHOULD COST LESS 20-30% PER TON THAN IN EUROPE / USA.

3. LOWER CAPITAL + MORE ENERGY (OCC) = FEASIBILITY.